

MODEL TA * \$%

FOR UP TO * \$ KGS

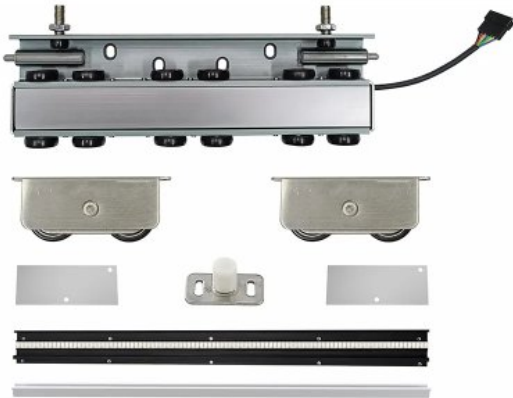

- For 700mm cabinet height
-) u :min 28mm- max 45mm
- Door Width: 950mm - 1200mm

Discover the future of entryway design with the TM 601, Tono's latest innovation. This automatic trackless door blends cutting-edge technology with sleek aesthetics, offering effortless movement and a minimalist look. Elevate your living or workspace with a design that's both functional and modern, crafted for those who demand the best. TM 601 – redefining the way we enter.

- Silent
- Reliable
- Sleek



MODEL TM 601

TECHNICAL SPECIFICATIONS

- 60 kgs max
- No exposed tracks, gears or scissors
- Quiet – runs at just 45 dB
- “Soft Start” and “Soft Stop” for smooth ride

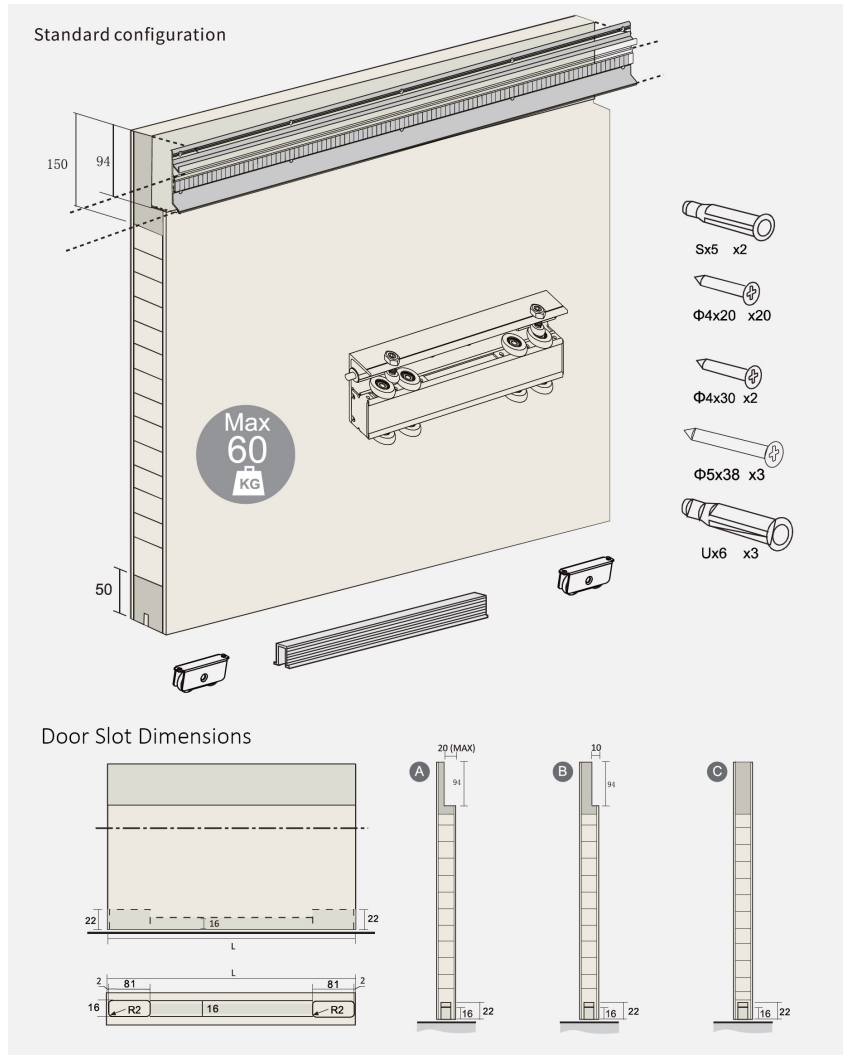

Side Door Clearance Dimensions: 28mm~max45mm

